

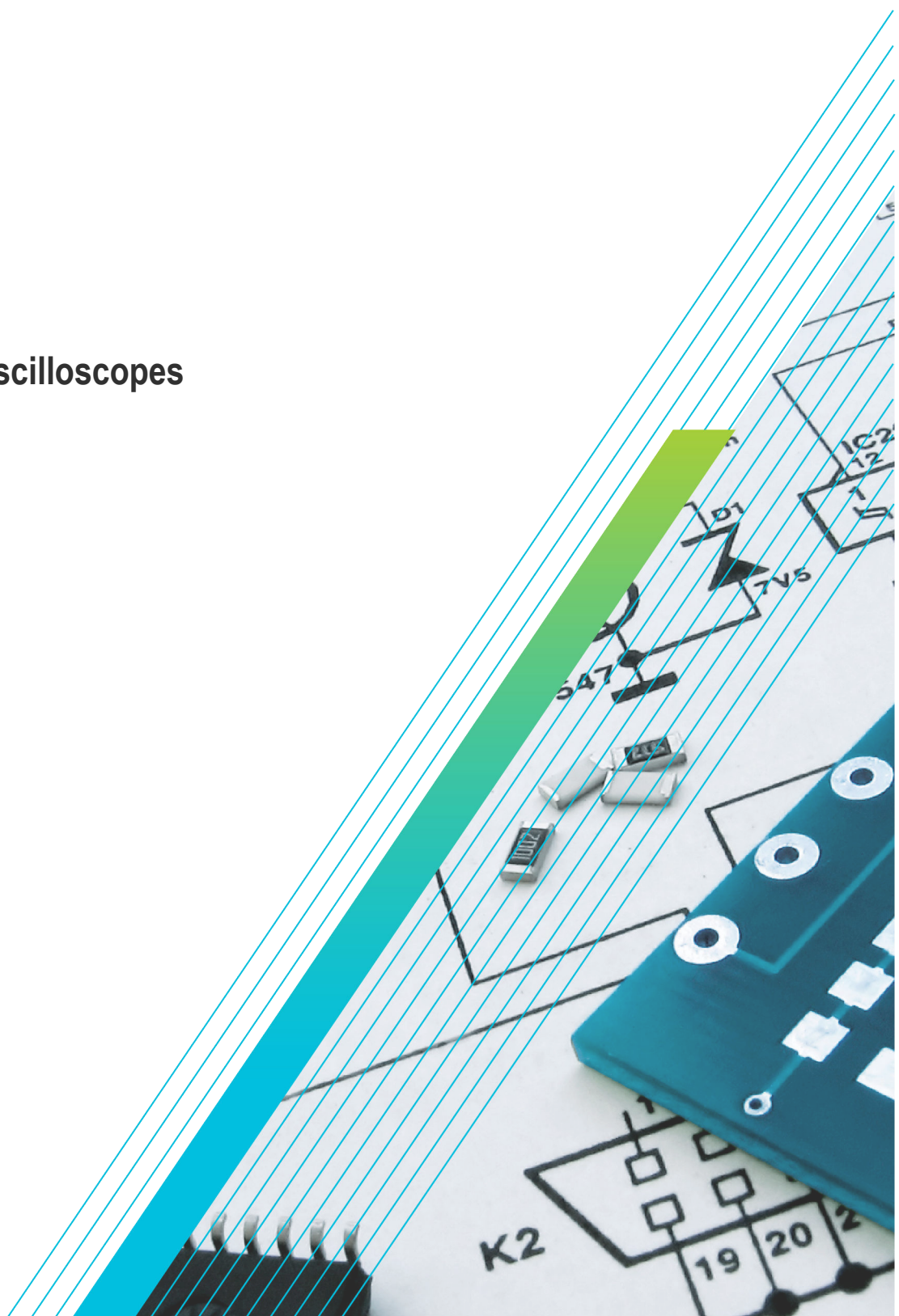

**TBS2000B Series
Digital Storage Oscilloscopes
Service Manual**



077-1539-01



**TBS2000B Series
Digital Storage Oscilloscopes
Service Manual**

Register now!
Click the following link to protect your product.
www.tek.com/register

Copyright © Tektronix. All rights reserved. Licensed software products are owned by Tektronix or its subsidiaries or suppliers, and are protected by national copyright laws and international treaty provisions. Tektronix products are covered by U.S. and foreign patents, issued and pending. Information in this publication supersedes that in all previously published material. Specifications and price change privileges reserved.

TEKTRONIX and TEK are registered trademarks of Tektronix, Inc.

Contacting Tektronix

Tektronix, Inc.

14150 SW Karl Braun Drive

P.O. Box 500

Beaverton, OR 97077

USA

For product information, sales, service, and technical support:

- In North America, call 1-800-833-9200.
- Worldwide, visit www.tek.com to find contacts in your area.

Table of Contents

List of Figures.....	vii
List of Tables.....	viii
Important safety information.....	ix
General safety summary.....	ix
Service safety summary.....	xi
Terms in the manual.....	xi
Symbols on the product.....	xi
Preface.....	xiii
Manual conventions.....	xiii
Modules.....	xiii
Replaceable parts.....	xiii
Safety.....	xiii
Ordering information.....	1
Theory of operation.....	2
Power supply.....	3
Front End assembly (4 channel models).....	3
Main board.....	3
I/O board (4 channel models).....	4
Front-panel board.....	4
Adjustments.....	5
Adjustments.....	5
Maintenance.....	6
Preventing ESD.....	6
Inspection and cleaning.....	6
General care.....	6
Flat panel display cleaning.....	6
Exterior cleaning.....	7
Interior cleaning.....	7
Lubrication.....	8
Module removal.....	8
Required tools and equipment.....	9
To remove modules.....	9
Troubleshooting.....	9
Adjustment after repair.....	9
Required tools and equipment.....	9
Troubleshooting procedure.....	9
Primary troubleshooting flowchart.....	10
AC Power Supply module troubleshooting flowchart.....	11
Board isolation troubleshooting flowchart.....	12
Unpacking and repacking instructions.....	12
Unpacking.....	12
Repacking.....	13
Storage.....	13
Replaceable parts.....	14

Parts ordering information.....	14
Part number revision level.....	14
Module servicing.....	14
Using the replaceable parts list.....	14
Abbreviations.....	15
Exploded view.....	15
The replaceable parts list.....	16

List of Figures

Figure 1: TBS2000B block diagram (2 channel).....	2
Figure 2: TBS2000B block diagram (4 channel).....	3
Figure 3: Primary troubleshooting procedure flowchart.....	10
Figure 4: AC Power Supply module troubleshooting.....	11
Figure 5: Board isolation troubleshooting flowchart.....	12
Figure 6: Four channel models; front half.....	16
Figure 7: Four channel models; rear half.....	18
Figure 8: Two channel models; front half.....	20
Figure 9: Two channel models; rear half.....	22

List of Tables

Table 1: External inspection checklist.....	7
Table 2: Internal inspection checklist.....	8
Table 3: Parts list column descriptions.....	15
Table 4: Four-channel model parts: front panel, display, and front chassis.....	16
Table 5: Four-channel model parts: inputs, main board, power supply, I/O, rear chassis, rear cover.....	18
Table 6: Two-channel model parts: front panel, display, and front chassis.....	20
Table 7: Two-channel model parts: power supply, main board, AC connector/filter, rear cover.....	22

Important safety information

This manual contains information and warnings that must be followed by the user for safe operation and to keep the product in a safe condition.

To safely perform service on this product, see the *Service safety summary* that follows the *General safety summary*.

General safety summary

Use the product only as specified. Review the following safety precautions to avoid injury and prevent damage to this product or any products connected to it. Carefully read all instructions. Retain these instructions for future reference.

This product shall be used in accordance with local and national codes.

For correct and safe operation of the product, it is essential that you follow generally accepted safety procedures in addition to the safety precautions specified in this manual.

The product is designed to be used by trained personnel only.

Only qualified personnel who are aware of the hazards involved should remove the cover for repair, maintenance, or adjustment.

Before use, always check the product with a known source to be sure it is operating correctly.

This product is not intended for detection of hazardous voltages.

Use personal protective equipment to prevent shock and arc blast injury where hazardous live conductors are exposed.

To avoid fire or personal injury

Use proper power cord	Use only the power cord specified for this product and certified for the country of use.
Ground the product	This product is grounded through the grounding conductor of the power cord. To avoid electric shock, the grounding conductor must be connected to earth ground. Before making connections to the input or output terminals of the product, ensure that the product is properly grounded. Do not disable the power cord grounding connection.
Power disconnect	The power switch disconnects the product from the power source. See instructions for the location. Do not position the equipment so that it is difficult to disconnect the power switch; it must remain accessible to the user at all times to allow for quick disconnection if needed.
Power disconnect	The power cord disconnects the product from the power source. See instructions for the location. Do not position the equipment so that it is difficult to operate the power cord; it must remain accessible to the user at all times to allow for quick disconnection if needed.
Connect and disconnect properly	Do not connect or disconnect probes or test leads while they are connected to a voltage source. Use only insulated voltage probes, test leads, and adapters supplied with the product, or indicated by Tektronix to be suitable for the product.
Observe all terminal ratings	To avoid fire or shock hazard, observe all rating and markings on the product. Consult the product manual for further ratings information before making connections to the product. Do not exceed the Measurement Category (CAT) rating and voltage or current rating of the lowest rated individual component of a product, probe, or accessory. Use caution when using 1:1 test leads because the probe tip voltage is directly transmitted to the product.

	Do not apply a potential to any terminal, including the common terminal, that exceeds the maximum rating of that terminal.
	Do not float the common terminal above the rated voltage for that terminal.
Do not operate without covers	Do not operate this product with covers or panels removed, or with the case open. Hazardous voltage exposure is possible.
Avoid exposed circuitry	Do not touch exposed connections and components when power is present.
Do not operate with suspected failures	If you suspect that there is damage to this product, have it inspected by qualified service personnel.
	Disable the product if it is damaged. Do not use the product if it is damaged or operates incorrectly. If in doubt about safety of the product, turn it off and disconnect the power cord. Clearly mark the product to prevent its further operation.
	Before use, inspect voltage probes, test leads, and accessories for mechanical damage and replace when damaged. Do not use probes or test leads if they are damaged, if there is exposed metal, or if a wear indicator shows.
	Examine the exterior of the product before you use it. Look for cracks or missing pieces.
	Use only specified replacement parts.
Use proper fuse	Use only the fuse type and rating specified for this product.
Wear eye protection	Wear eye protection if exposure to high-intensity rays or laser radiation exists.
Do not operate in wet/damp conditions	Be aware that condensation may occur if a unit is moved from a cold to a warm environment.
Do not operate in an explosive atmosphere	
Keep product surfaces clean and dry	Remove the input signals before you clean the product.
Provide proper ventilation	Refer to the installation instructions in the manual for details on installing the product so it has proper ventilation.
	Slots and openings are provided for ventilation and should never be covered or otherwise obstructed. Do not push objects into any of the openings.
Provide a safe working environment	Always place the product in a location convenient for viewing the display and indicators.

Probes and test leads

Before connecting probes or test leads, connect the power cord from the power connector to a properly grounded power outlet.

Keep fingers behind the protective barrier, protective finger guard, or tactile indicator on the probes.

Remove all probes, test leads and accessories that are not in use.

Use only correct Measurement Category (CAT), voltage, temperature, altitude, and amperage rated probes, test leads, and adapters for any measurement.

Beware of high voltages

Understand the voltage ratings for the probe you are using and do not exceed those ratings. Two ratings are important to know and understand:

- The maximum measurement voltage from the probe tip to the probe reference lead
- The maximum floating voltage from the probe reference lead to earth ground

These two voltage ratings depend on the probe and your application. Refer to the Specifications section of the manual for more information.



Warning: To prevent electrical shock, do not exceed the maximum measurement or maximum floating voltage for the oscilloscope input BNC connector, probe tip, or probe reference lead.

Connect and disconnect properly	Connect the probe output to the measurement product before connecting the probe to the circuit under test. Connect the probe reference lead to the circuit under test before connecting the probe input. Disconnect the probe input and the probe reference lead from the circuit under test before disconnecting the probe from the measurement product.
Connect and disconnect properly	De-energize the circuit under test before connecting or disconnecting the current probe. Connect the probe reference lead to earth ground only. Do not connect a current probe to any wire that carries voltages or frequencies above the current probe voltage rating.
Inspect the probe and accessories	Before each use, inspect probe and accessories for damage (cuts, tears, or defects in the probe body, accessories, or cable jacket). Do not use if damaged.

Service safety summary

The *Service safety summary* section contains additional information required to safely perform service on the product. Only qualified personnel should perform service procedures. Read this *Service safety summary* and the *General safety summary* before performing any service procedures.

To avoid electric shock	Do not touch exposed connections.
Do not service alone	Do not perform internal service or adjustments of this product unless another person capable of rendering first aid and resuscitation is present.
Disconnect power	To avoid electric shock, switch off the product power and disconnect the power cord from the mains power before removing any covers or panels, or opening the case for servicing.
Use care when servicing with power on	Dangerous voltages or currents may exist in this product. Disconnect power, remove battery (if applicable), and disconnect test leads before removing protective panels, soldering, or replacing components.
Verify safety after repair	Always recheck ground continuity and mains dielectric strength after performing a repair.

Terms in the manual

These terms may appear in this manual:



Warning: Warning statements identify conditions or practices that could result in injury or loss of life.



CAUTION: Caution statements identify conditions or practices that could result in damage to this product or other property.

Symbols on the product

These terms may appear on the product:

- DANGER indicates an injury hazard immediately accessible as you read the marking.
- WARNING indicates an injury hazard not immediately accessible as you read the marking.
- CAUTION indicates a hazard to property including the product.



When this symbol is marked on the product, be sure to consult the manual to find out the nature of the potential hazards and any actions which have to be taken to avoid them. (This symbol may also be used to refer the user to ratings in the manual.)

The following symbols may appear on the product:



CAUTION Refer to Manual Protective Ground (Earth) Terminal Earth Terminal Chassis Ground Standby

Preface

This service manual provides information that you need to troubleshoot, disassemble, and replace parts on the following Tektronix oscilloscopes:

Model	Bandwidth	Channels
TBS2072B	70 MHz	2
TBS2102B	100 MHz	2
TBS2202B	200 MHz	2
TBS2074B	70 MHz	4
TBS2104B	100 MHz	4
TBS2204B	200 MHz	4

Manual conventions

This manual uses certain conventions that you should become familiar with before performing service.

Modules

Throughout this manual, any replaceable component, assembly, or part is referred to by the term module.

Replaceable parts

This manual refers to any field-replaceable assembly or mechanical part specifically by its name or generically as a replaceable part. In general, a replaceable part is any circuit board or assembly, (such as the hard disk drive), or a mechanical part, (such as the I/O port connectors), that is listed in the replaceable parts list that can be replaced in the field. (See [The replaceable parts list](#) on page 16.)

Safety

Symbols and terms related to safety appear in the *General Safety Summary*.

Information for service procedures appears in both the *General Safety Summary* and the *Service Safety Summary*.

Ordering information

For information on installing and operating your oscilloscope, refer to the TBS2000B Series Digital Storage Oscilloscopes User Manual (Tektronix part number 077-1525-xx English; other languages available), which is downloadable from the Tektronix Web site (www.tek.com/downloads).

Theory of operation

This chapter describes the electrical operation of the oscilloscope to the module level. The block diagrams shows the oscilloscope module interconnections.

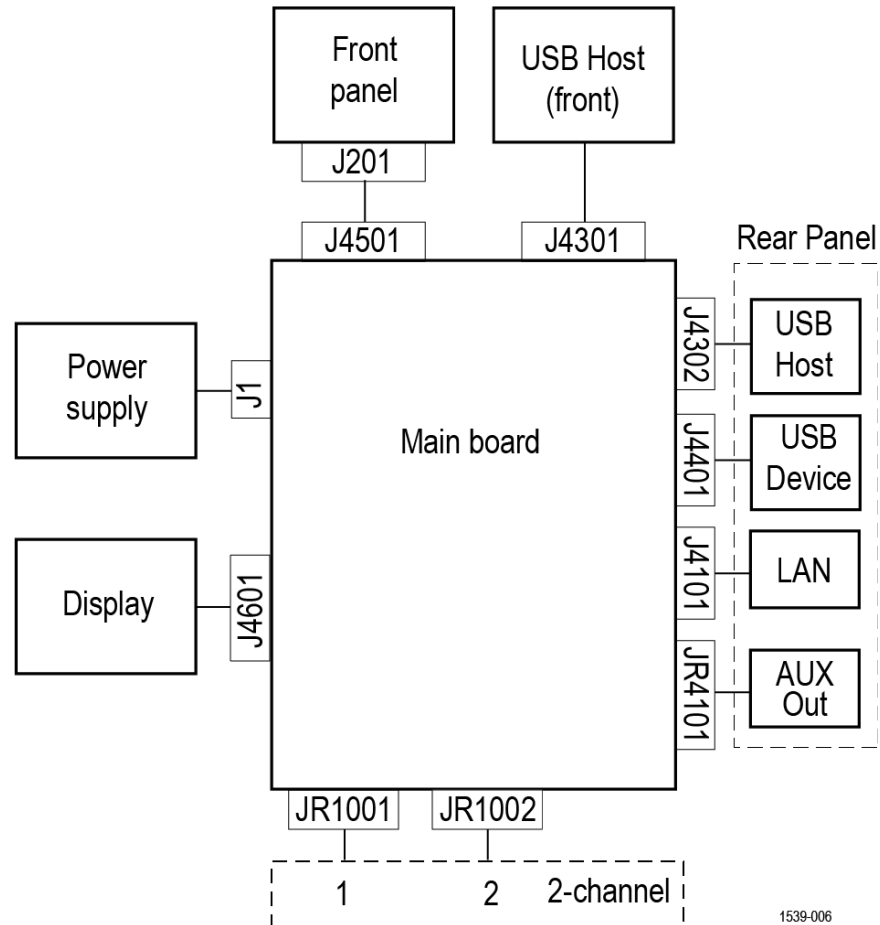

Figure 1: TBS2000B block diagram (2 channel)

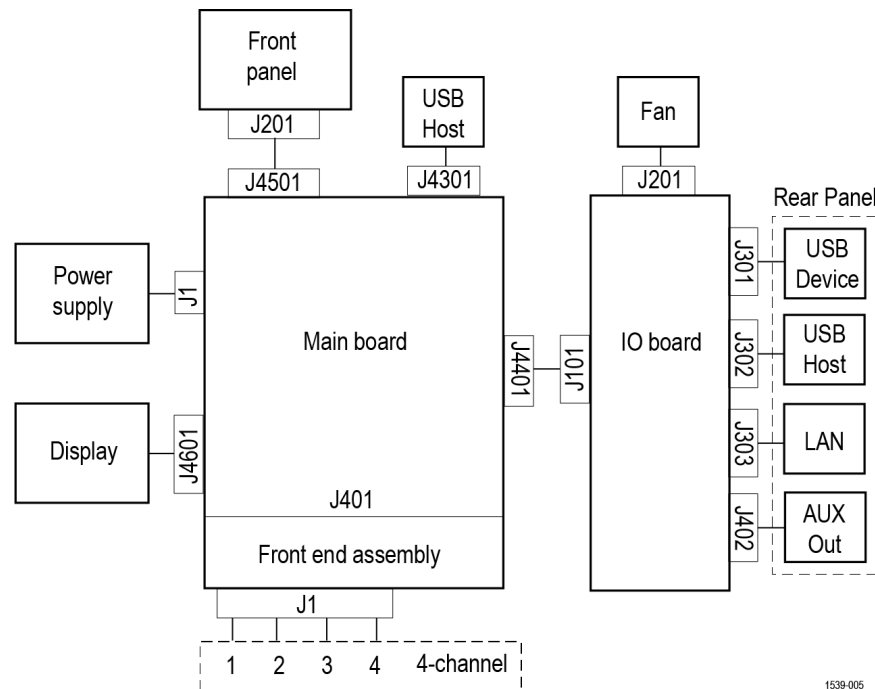

Figure 2: TBS2000B block diagram (4 channel)

Power supply

The Power Supply board converts AC line voltage to +12 V to power for all internal circuits.

Front End assembly (4 channel models)

The Front End assembly begins with the analog signal path and ends with differential mode channel signals which are passed to the Main board. The analog inputs, attenuators, and preamps are contained in this assembly.

Main board

The Main boards contain the following functions:

Acquisition system

The Acquisition system begins with the analog signal path and ends with a digitized signal in memory. The signal enters a channel input, and then passes through an attenuator and preamplifier. The analog signal from each preamplifier goes through a digitizer, and then into acquisition memory. The analog signal from each preamplifier is also distributed to a trigger circuit.

Trigger system

The Trigger system digitizes the analog signals from the preamplifiers and routes the digitized signal to the Trigger circuit. Advanced trigger functions are enabled only when the appropriate application modules and supporting software are installed.

Display system

The Display system combines live waveform data from acquisition memory with menus and text, and stores this information in display memory. It then uses this data to refresh the XGA display module (LCD).

Processor system

The Processor system contains an ARM microprocessor that controls the entire instrument. The processor system also contains FLASH ROM, system RAM, and interfaces to USB ports and the Ethernet port.

Power subsystem

The Main board converts the +12 V power to +5 V, -5 V, +3.3 V, +2.5 V, +2 V, +1.8 V, +1.5 V, +1.1 V, 1 V, and 0.75 V, used by circuitry throughout the system. The Front Panel board is powered on at all times when AC power is connected to the unit.

I/O ports (2 channel models)

The Main board provides USB ports (Host and Device), an Ethernet port (LAN), and an Aux Out trigger output connections.

I/O board (4 channel models)

The I/O board provides USB ports (Host and Device), an Ethernet port (LAN), and an Aux Out trigger output connections.

Front-panel board

The Front Panel board contains a microprocessor that reads the front-panel buttons and controls, sends this information to the processor system on the Main board, and controls power to the Main board. The Front Panel board also generates the probe compensation output signal and controls power to the Main board.

Adjustments

Adjustments

There are no customer-performable adjustment procedures (calibrations) for the TBS2000B Series oscilloscopes. Please return the instrument to Tektronix if adjustment is required. Calibrations can only be performed at a Tektronix service center and require the use of traceable test equipment (signal sources and measuring equipment) to verify the performance of the instrument.

To determine if adjustment is required, use the Performance Verification procedure in the TBS2000B Series Digital Storage Oscilloscopes Specifications and Performance Verification manual (tektronix part number 077-1148-xx), available at www.tek.com/downloads. Adjustment is also required after instrument repair.

Maintenance

This section contains the information needed to do periodic and corrective maintenance on the oscilloscope, and repackaging instructions for returning the oscilloscope to Tektronix for service.

Preventing ESD

Before servicing this product, read the *General Safety Summary* and the *Service Safety Summary* at the front of the manual, as well as the following ESD information.



CAUTION: Electrostatic discharge (ESD) can damage any semiconductor component in this instrument.

When performing any service that requires internal access to the instrument, adhere to the following precautions to avoid damaging internal modules and their components due to electrostatic discharge:

1. Minimize handling of static-sensitive circuit boards and components.
2. Transport and store static-sensitive modules in their static protected containers or on a metal rail. Label any package that contains static-sensitive boards.
3. Discharge the static voltage from your body by wearing a grounded antistatic wrist strap while handling these modules.
4. Service static-sensitive modules only at a static-free work station.
5. Do not allow any items capable of generating or holding a static charge on the work station surface.
6. Handle circuit boards by the edges when possible.
7. Do not slide the circuit boards over any surface.
8. Avoid handling circuit boards in areas that have a floor or work-surface covering capable of generating a static charge.

Inspection and cleaning

Inspection and Cleaning describes how to inspect for dirt and damage. It also describes how to clean the exterior and interior of the instrument. Inspection and cleaning are done as preventive maintenance. Preventive maintenance, when done regularly, may prevent instrument malfunction and enhance its reliability.

Preventive maintenance consists of visually inspecting and cleaning the instrument and using general care when operating it.

How often to perform maintenance depends on the severity of the environment in which the instrument is used. A proper time to perform preventive maintenance is just before instrument adjustment.

General care

The cabinet helps keep dust out of the oscilloscope and should normally be in place when operating the oscilloscope.



Warning: To avoid injury, power off the instrument and disconnect it from line voltage before performing any procedure that follows.

Flat panel display cleaning

Clean the flat panel display surface by gently rubbing the display with a clean-room wipe (such as Wypall Medium Duty Wipes, #05701, available from Kimberly-Clark Corporation), or an abrasive-free cleaning cloth.

If the display is very dirty, moisten the wipe or cloth with distilled water, a 75% isopropyl alcohol solution, or standard glass cleaner, and gently rub the display surface. Use only enough liquid to dampen the cloth or wipe. Avoid using excess force or you may damage the display surface.



CAUTION: Improper cleaning agents or methods can damage the flat panel display.

- Do not use abrasive cleaners or surface cleaners to clean the display.
- Do not spray liquids directly on the display surface.
- Do not scrub the display with excessive force.



CAUTION: To prevent getting moisture inside the instrument during external cleaning, do not spray any cleaning solutions directly onto the screen or instrument.

Exterior cleaning

Clean the exterior surfaces of the chassis with a dry lint-free cloth or a soft-bristle brush. If any dirt remains, use a cloth or swab dipped in a 75% isopropyl alcohol solution. Use a swab to clean narrow spaces around controls and connectors. Do not use abrasive compounds on any part of the chassis that may damage the chassis.

Clean the On/Standby switch using a cleaning towel dampened with deionized water. Do not spray or wet the switch itself.



CAUTION: Avoid the use of chemical cleaning agents which might damage the plastics used in this instrument. Use only deionized water when cleaning the front-panel buttons. Use a 75% isopropyl alcohol solution as a cleaner for cabinet parts. Before using any other type of cleaner, consult your Tektronix Service Center or representative.

Inspection - Exterior. Inspect the outside of the instrument for damage, wear, and missing parts. Immediately repair defects that could cause personal injury or lead to further damage to the instrument.

Table 1: External inspection checklist

Item	Inspect for	Repair action
Cabinet, front panel, and cover	Cracks, scratches, deformations, damaged hardware	Repair or replace defective module
Front-panel knobs	Missing, damaged, or loose knobs	Repair or replace missing or defective knobs
Connectors	Broken shells, cracked insulation, and deformed contacts. Dirt in connectors	Repair or replace defective modules. Clear or brush out dirt
Carrying handle and cabinet feet	Correct operation	Repair or replace defective module
Accessories	Missing items or parts of items, bent pins, broken or frayed cables, and damaged connectors	Repair or replace damaged or missing items, frayed cables, and defective modules

Interior cleaning

You can only clean the interior of the rear chassis assembly. To access the rear chassis assembly, see the *Removal and Installation Procedures* topics.

Do not disassemble or clean the front chassis assembly (other than cleaning the front panel display and removing panel knobs). Disassembling the front chassis assembly requires that the instrument be returned to your nearest Tektronix Service Center for calibration.



Warning: To avoid electric shock or damage to the instrument, remove instrument power. Before performing any procedure that follows, power down the instrument and disconnect it from line voltage.

- Blow off dust with dry, low-pressure (approximately 9 psi), deionized air.
- Use a soft-bristle, non-static-producing brush for cleaning around components.

- Remove any remaining dust with a lint-free cloth dampened in isopropyl alcohol (75% solution). (A cotton-tipped applicator is useful for cleaning in narrow spaces and on circuit boards).
- If you must use a liquid for minor rear chassis interior cleaning, use a clean-room wipe (such as Wypall Medium Duty Wipes, #05701, available from Kimberly-Clark Corporation) dampened with a 75% isopropyl alcohol solution.
- Inspect the internal portions of the instrument for damage and wear. See [Table 2: Internal inspection checklist](#) on page 8. Defects should be repaired immediately.
- If any circuit board is repaired or replaced, you must perform the Performance Verification procedure in the specifications and performance verification manual, which was provided with your instrument. This manual is also available at www.tektronix.com/manuals, by searching for your product name. If the instrument fails the Performance Verification tests, it must be returned to a Tektronix Service Center for repair and calibration.



CAUTION: To prevent damage from electrical arcing, ensure that circuit boards and components are dry before applying power to the instrument.

Table 2: Internal inspection checklist

Item	Inspect for	Repair action
Circuit boards	Loose, broken, or corroded solder connections. Burned circuit boards. Burned, broken, or cracked circuit-run plating.	Remove and replace damaged circuit board.
Resistors	Burned, cracked, broken, blistered condition.	
Capacitors	Damaged or leaking cases. Corroded solder on leads or terminals.	
Wiring and cables	Loose plugs or connectors. Burned, broken, or frayed wiring.	Firmly seat connectors. Replace defective cables.
Chassis	Dents, deformations, and damaged hardware.	Straighten, repair, or replace defective hardware.

Lubrication

There is no periodic lubrication required for this instrument.

Module removal



Warning: Only qualified personnel should perform service procedures. Before performing this or any other procedure in this manual, read the General Safety Summary and Service Safety Summary located at the beginning of this manual. Also, to prevent possible injury to service personnel or damage to electrical components, read Preventing ESD. (See [Preventing ESD](#) on page 6.)

To remove an assembly, refer to the exploded view diagrams and parts lists. (See [The replaceable parts list](#) on page 16.)

If you are disassembling the instrument for cleaning, refer to the Inspection and Cleaning procedure for instructions. (See [Inspection and cleaning](#) on page 6)



Warning: Disconnect the power cord from the line voltage source. Failure to do so could cause serious injury or death.

Required tools and equipment

About this task

You need the following equipment to troubleshoot the instrument.

Tools and equipment	Example
DMM	3.5 digits or above

To remove modules

About this task

- To remove any of the instrument modules or assemblies, you must first remove the rear cover and separate the front chassis from the rear chassis.
- To remove the Front Panel board assembly or the front panel case assembly, you must first remove the Main board assembly and the front chassis.
- To remove or install the keypad, do not touch the switch contacts with your fingers. The oils on your fingers will degrade or damage the switch contacts.

To help prevent damage to the keypad, use cotton gloves when removing or installing the keyboard pad.

Troubleshooting



CAUTION: Before performing this or any other procedure in this manual, read the General Safety Summary and Service Safety Summary found at the beginning of this manual.

To prevent possible injury to service personnel or damage to electrical components, please read information on Preventing ESD. (See [Preventing ESD](#) on page 6.)

This section contains information and procedures designed to help you isolate faults to a module.

This section requires that service personnel have the appropriate skills to work on this instrument, including PC troubleshooting and Microsoft Windows operating system skills. Details of PC and Windows operation and service are not in this manual.

For assistance, contact your local Tektronix Service Center.

Adjustment after repair

Instrument adjustment is required after you replace the Main board (all models) or the Front End assembly (4 channel models). Refer to the Adjustments section for information about the adjustment. (See [Adjustments](#) on page 5.)

Required tools and equipment

About this task

You need the following equipment to troubleshoot the instrument.

Tools and equipment	Example
DMM	3.5 digits or above

Troubleshooting procedure

Use the following flowcharts to troubleshoot an instrument failure. Begin with the Primary troubleshooting flowchart.



Warning: Before removing the cabinet, disconnect the power cord from the line voltage source. Failure to do so could cause serious injury or death.



CAUTION: When you operate the four-channel instrument with the cabinet removed, the system fan will not cool the instrument. You must provide an external fan to cool the interior of the instrument. Failure to do so could cause instrument damage.

Primary troubleshooting flowchart

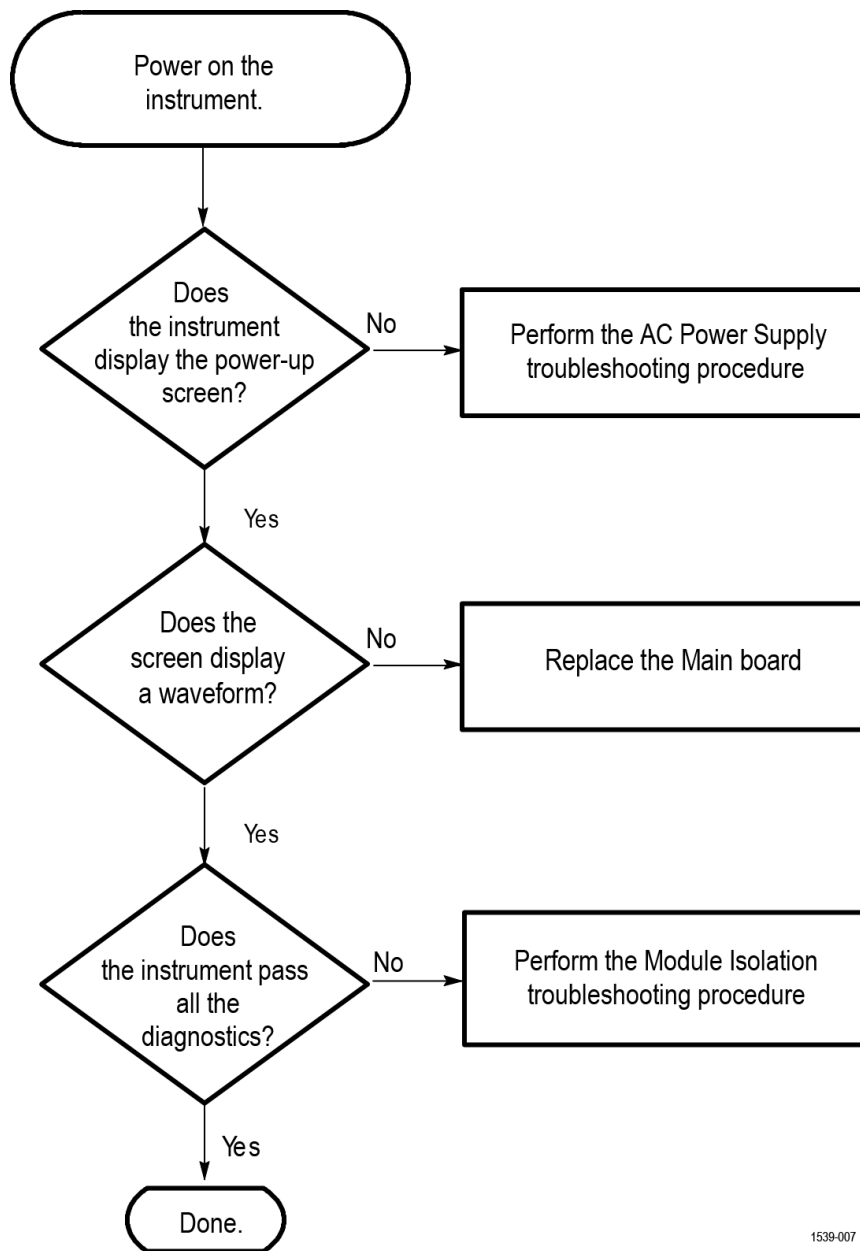

1539-007

Figure 3: Primary troubleshooting procedure flowchart

AC Power Supply module troubleshooting flowchart

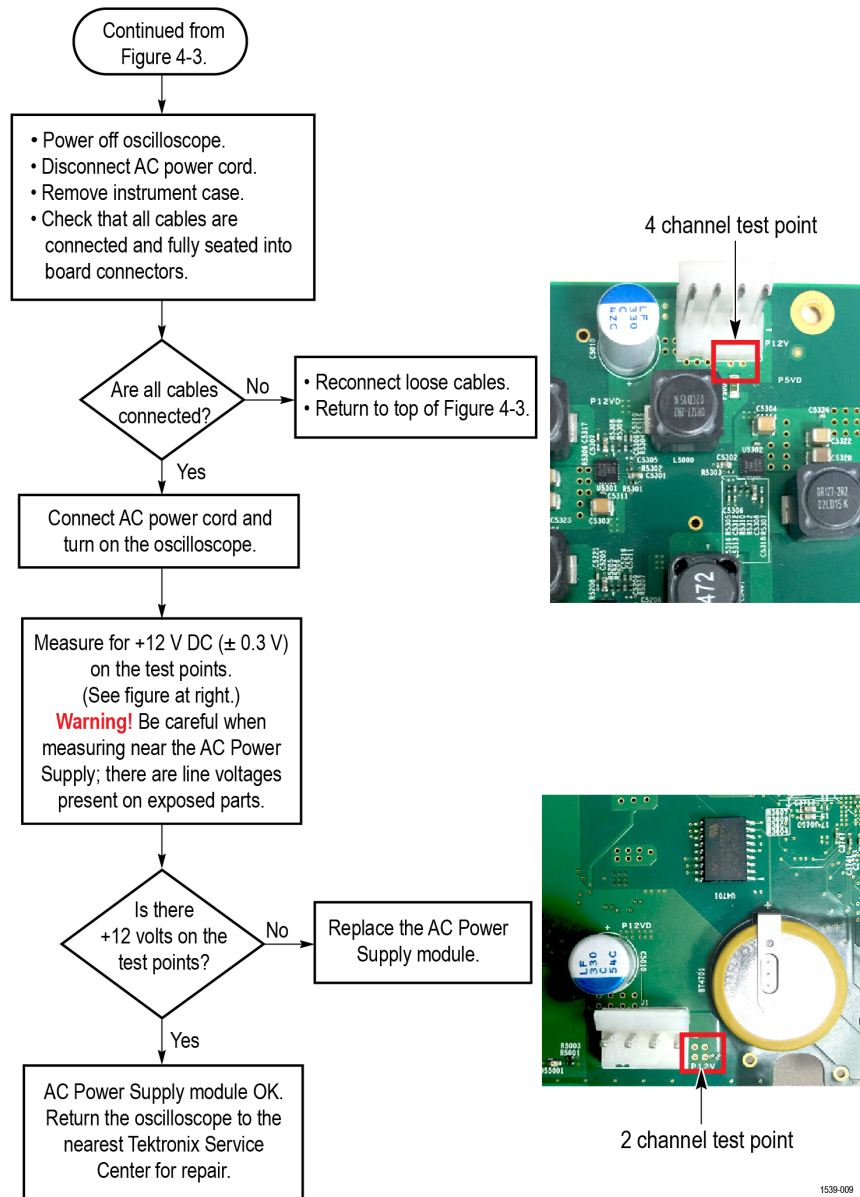
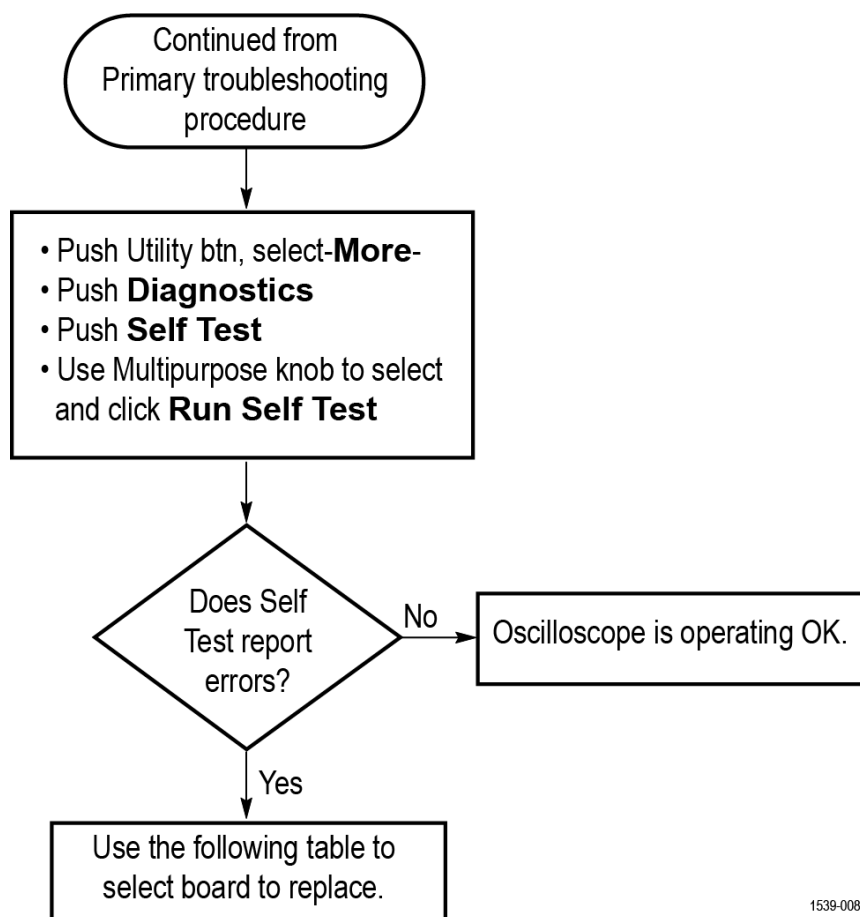

Figure 4: AC Power Supply module troubleshooting



Note: Images show the power supply cable disconnected from the main board, to better show the test point locations. The power cable from the Power Supply must be connected to the Main board to test the +12 VDC value.

Board isolation troubleshooting flowchart



1539-008

Figure 5: Board isolation troubleshooting flowchart

Failed test	Most likely board
CPU	Main
Display	Main
Acquisition	Main (or Front End board on 4-channel models)
ROM	Main
Front Panel	Front Panel or Main
I/O	Main (or I/O board on 4-channel models)

Unpacking and repacking instructions

This section contains the information needed to unpack the oscilloscope and repack it for shipment or storage.

Unpacking

The oscilloscope and its standard accessories are carefully packed at the factory in a shipping carton. If, upon receipt, damage to the shipping carton is evident, tell the shipper. Tektronix, Inc. is not responsible for damage caused during shipping.

If you have not already done so, carefully remove the oscilloscope and its accessories from the shipping carton and inspect them for damage. Save the shipping carton for repacking or storage.

Repacking

Use a corrugated cardboard shipping carton having a test strength of at least 275 pounds (125 kg) and with an inside dimension at least six inches (15.25 cm) greater than the instrument dimensions.

If the instrument is being shipped to a Tektronix Service Center, enclose the following information:

- The owner's address
- Name and phone number of a contact person
- Type and serial number of the instrument
- Reason for returning
- A complete description of the service required

Seal the shipping carton with an industrial stapler or strapping tape.

Mark the address of the Tektronix Service Center and also your own return address on the shipping carton in two prominent locations. See www.tektronix.com/service to find a service center near you.

Storage

The oscilloscope should be stored in a clean, dry environment. The following environmental characteristics apply for both shipping and storage:

- Temperature range: -4 °F to +140 °F (-20 °C to +60 °C)
- Altitude: To 39,370 feet (12,000 m)

See the Tektronix TBS2000B Series Digital Storage Oscilloscopes Specifications and Performance Verification Technical Reference (Tektronix part number 077-1148-xx) for a complete listing of the environmental specifications.

Replaceable parts

Parts ordering information

Replacement parts are available through your local Tektronix field office or representative.

Changes to Tektronix products are sometimes made to accommodate improved components as they become available and to give you the benefit of the latest improvements. Therefore, when ordering parts, it is important to include the following information in your order:

- Part number
- Instrument type or model number
- Instrument serial number
- Instrument modification number, if applicable

If you order a part that has been replaced with a different or improved part, your local Tektronix field office or representative will contact you concerning any change in part number.

Part number revision level

Tektronix part numbers contain two digits that show the revision level of the part. For some parts in this manual, you will find the letters “xx” in place of the revision level number.



When you order parts, Tektronix will provide you with the most current part for your product type, serial number, and modification (if applicable). At the time of your order, Tektronix will determine the part number revision level needed for your product, based on the information you provide.

Module servicing

Modules can be serviced by selecting one of the following three options. Contact your local Tektronix Service Center or representative for repair assistance.

Module exchange. In some cases, you may exchange your module for a remanufactured module. These modules cost significantly less than new modules and meet the same factory specifications. For more information about the module exchange program, call 1-800-833-9200. Outside North America, contact a Tektronix sales office or distributor; see the Tektronix Web site (www.tek.com) for a list of offices.

Module repair and return. You may ship your module to us for repair, after which we will return it to you.

New modules. You may purchase replacement modules in the same way as other replacement parts.

Using the replaceable parts list

This section contains a list of the replaceable mechanical and/or electrical components. Use this list to identify and order replacement parts. The following table describes each column in the parts list.

Table 3: Parts list column descriptions

Column	Column name	Description
1	Figure & index number	Items in this section are referenced by figure and index numbers to the exploded view illustrations that follow.
2	Tektronix part number	Use this part number when ordering replacement parts from Tektronix.
3 and 4	Serial number	Column three indicates the serial number at which the part was first effective. Column four indicates the serial number at which the part was discontinued. No entry indicates the part is good for all serial numbers.
5	Qty	This indicates the quantity of parts used.
6	Name & description	An item name is separated from the description by a colon (:). Because of space limitations, an item name may sometimes appear as incomplete. Use the U.S. Federal Catalog handbook H6-1 for further item name identification.

Abbreviations

Abbreviations conform to American National Standard ANSI Y1.1-1972.

Exploded view

The illustrations in this section show the module-level exploded views of the oscilloscopes. Each exploded view is indexed by the numbers in the figure. The table of index numbers and part numbers corresponding to a picture are in the table immediately preceding the illustration.

The replaceable parts list

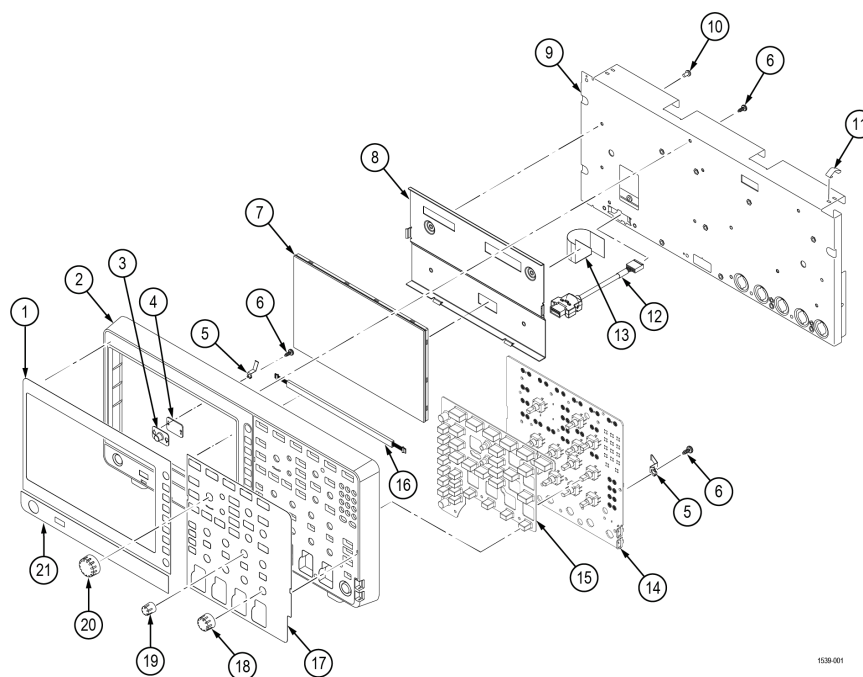

Figure 6: Four channel models; front half

Table 4: Four-channel model parts: front panel, display, and front chassis

Fig. & index number	Tektronix part number	Serial no. effective	Serial no. discont'd	Qty ¹	Name & description
5-1-1	335-4044-xx			1	LABLE, BLACK FRAME-B4 9 INCH DISPLAY
-2	850-0440-xx			1	FRONT CASE
-3	260-3115-xx			1	SWITCH, KEYPAD, ELASTOMERIC POWER; SAFETY CONTROLLED
-4	878-1179-xx			1	CIRCUIT BOARD ASSY; POWER SWITCH BOARD
-5	131-8139-xx			8	CONTACT, SPRING; FRONT PANEL ELEC
-6	211-1273-xx			22 ²	SCREW, PT; K35-1.57, PAN HEAD, STL, ZNPL, T-15
-7	850-0312-xx			1	FRAME ASSEMBLY; DISPLAY; TBS2K
-8	407-5760-xx			1	BRACKET, DISPLAY MOUNT
-9	441-2848-xx			43 ²	CHASSIS, FRONT
-10	211-1272-xx			6	SCREW, MACHINE; 6-32 X 0.250, PNH, STL, ZNPL, T-15 TORX DR
-11	131-6643-xx			1	CONTACT, ELECTRICAL
12	174-5411-xx			1	CABLE EXTENSION, USB-HOST

Table continued...

¹ Quantity indicated is for the entire instrument, not necessarily for each image.

² Tightening torque for 211-1272-xx and 211-1273-xx is 0.9 N*M

Fig. & index number	Tektronix part number	Serial no. effective	Serial no. discount'd	Qty ¹	Name & description
-13	174-6623-xx			1	CABLE, DISPLAY, FFC, 50POS
-14	870-1172-xx			1	PCB, FRONT-PANEL
-15	260-3115-xx			1	SWITCH, KEYPAD, ASSEMBLY FRONT
-16	174-6696-xx			1	CABLE CONNECTION, FRONT-PANEL & POWER SWITCH
-17	335-4044-xx			1	MARKER, IDENTIFICATION LABEL, SAFETY CONTROLLED
	335-4155-xx			1	MARKER, IDENTIFICATION FRONT PANEL OVERLAY, KOREAN
	335-4147-xx			1	MARKER, IDENTIFICATION FRONT PANEL OVERLAY, FRENCH
	335-4156-xx			1	MARKER, IDENTIFICATION FRONT PANEL OVERLAY, RUSSIAN
	335-4148-xx			1	MARKER, IDENTIFICATION FRONT PANEL OVERLAY, ITALIAN
	335-4149-xx			1	MARKER, IDENTIFICATION FRONT PANEL OVERLAY, GERMAN
	335-4150-xx			1	MARKER, IDENTIFICATION FRONT PANEL OVERLAY, SPANISH
	335-4151-xx			1	MARKER, IDENTIFICATION FRONT PANEL OVERLAY, JAPANESE
	335-4153-xx			1	MARKER, IDENTIFICATION FRONT PANEL OVERLAY, SIMPLE CHINESE
	335-4154-xx			1	MARKER, IDENTIFICATION FRONT PANEL OVERLAY, STANDARD CHINESE
-18	366-0935-xx			5	ASSEMBLY, KNOB; .685 DIAMETER
-19	366-0934-xx			6	ASSEMBLY, KNOB; .470 DIAMETER
-20	366-0936-xx			1	ASSEMBLY, KNOB; .925 DIAMETER
-21	335-4113-xx			1	MARKER, IDENTIFICATION LABEL, SAFETY CONTROLLED
-22	335-4117-xx			1	LABEL, NOMENCLATURE, TBS2074B
	335-4116-xx			1	LABEL, NOMENCLATURE, TBS2104B
	335-4093-xx			1	LABEL, NOMENCLATURE, TBS2204B

¹ Quantity indicated is for the entire instrument, not necessarily for each image.

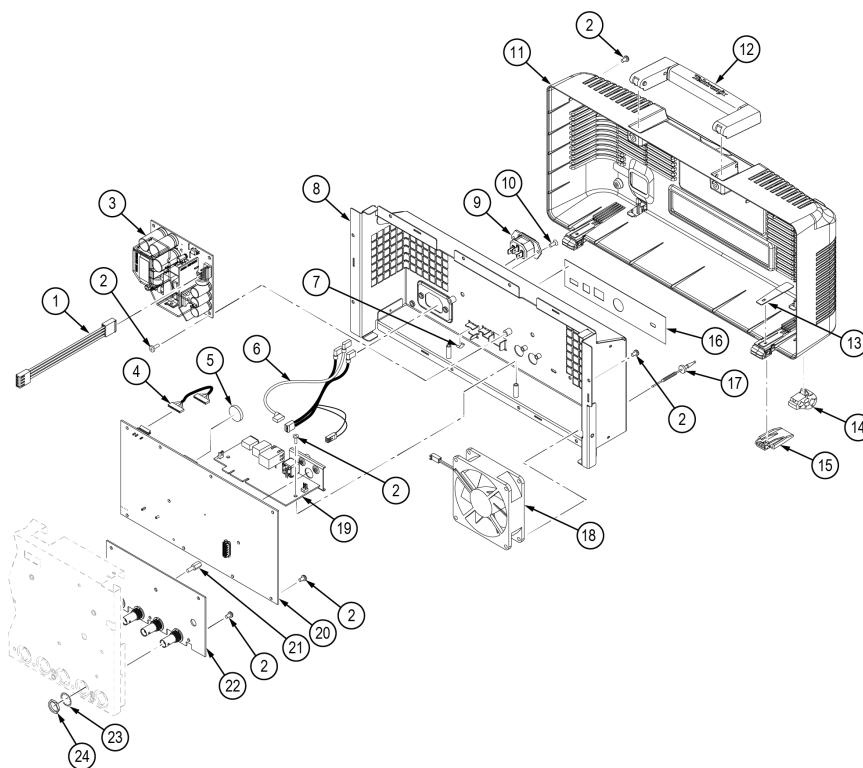

Figure 7: Four channel models; rear half

Table 5: Four-channel model parts: inputs, main board, power supply, I/O, rear chassis, rear cover

Fig. & index number	Tektronix part number	Serial no. effective	Serial no. discontinued	Qty ¹	Name & description
5-2-1	174-6877-xx			1	CABLE POWER SUPPLY WITH MAIN BOARD, SAFETY CONTROLLED
-2	211-1272-xx			43 ²	SCREW, MACHINE; 6-32 X 0.250, PNH, STL, ZNPL, T-15 TORX DR
-3	119-8488-xx			1	POWER SUPPLY; AC-DC, INTERNAL; 90-264 VAC 47-63 HZ, 103-127 VAC 360-440 HZ IN; +12V 5A4, 65W OUT; SAFETY CONTROLLED
-4	174-6699-xx			1	CABLE CONNECTION, FRONT-PANEL & MAIN BOARD
-5	146-0148-xx			1	BATTERY, DRY: 3 VOLT, 150MAH, LITHIUM, LEADED BUTTON CELL, SAFETY CONTROLLED
-6	174-6286-xx			1	CABLE ASSEMBLY (LINE INPUT), SAFETY CONTROLLED
-7	131-6643-xx			2	CONTACT, ELECTRICAL
-8	441-2847-xx			1	CHASSIS; REAR, SAFETY CONTROLLED

Table continued...

Fig. & index number	Tektronix part number	Serial no. effective	Serial no. discount'd	Qty ¹	Name & description
-9	119-7086-xx			1	FILTER, EMI; AC LINE CONNECTOR/INPUT FILTER; 6.0A, 120-250VAC, DC-400 HZ
-10	211-0718-xx			2	SCREW, MACHINE; 6-32 X 0.312, FLH100, STEEL, ZINC FINISH, T-10 TORX DR
-11	850-0443-xx			1	CASE, REAR, SAFETY CONTROLLED
-12	367-0598-xx			1	HANDLE, CARRYING OVERMOLDED, SAFETY CONTROLLED
-13	214-5148-xx			2	SPRING FRONT FOOT
-14	348-1909-xx			2	FOOT REAR
-15	348-2222-xx			2	FOOT, FRONT CABINET, HINGED
-16	335-3427-xx			1	LABEL, IO (REAR)
-17	213-1150-xx			4	SCREW, FLAT HEAD, T15 FAN SCREW, M5X10
-18	119-8751-xx			1	FAN, TUBE AXIAL (92MM, DC, ASSEMBLY)
-19	878-1137-xx			1	CIRCUIT BOARD (IO BOARD)
-20	870-1169-xx			1	CIRCUIT BOARD MAIN BOARD
-21	129-1693-xx			1 ³	SCREW, JACK, 433H, 6-32 INTERNAL, 8-32 EXTERNAL
-22	878-1139-xx			1	CIRCUIT BOARD ASSY, ANALOG FRONT END BOARD,
-23	210-1039-xx			4	WASHER, LOCK INTERNAL TOOTH
-24	220-0265-xx			4 ⁴	NUT, PLAIN, HEX; 0.5-28 X 0.625 HEX, BRS, NKL PL
-N/A	119-8771-xx			1 ⁵	WIFI USB DONGLE FOR TBS

³ Tightening torque for 129-1693-xx is 1.13 N*M.

⁴ Tightening torque for 220-0265-xx is 4.52N*M, ±0.23 N*M.

⁵ Tektronix option TEKUSBWIFI.

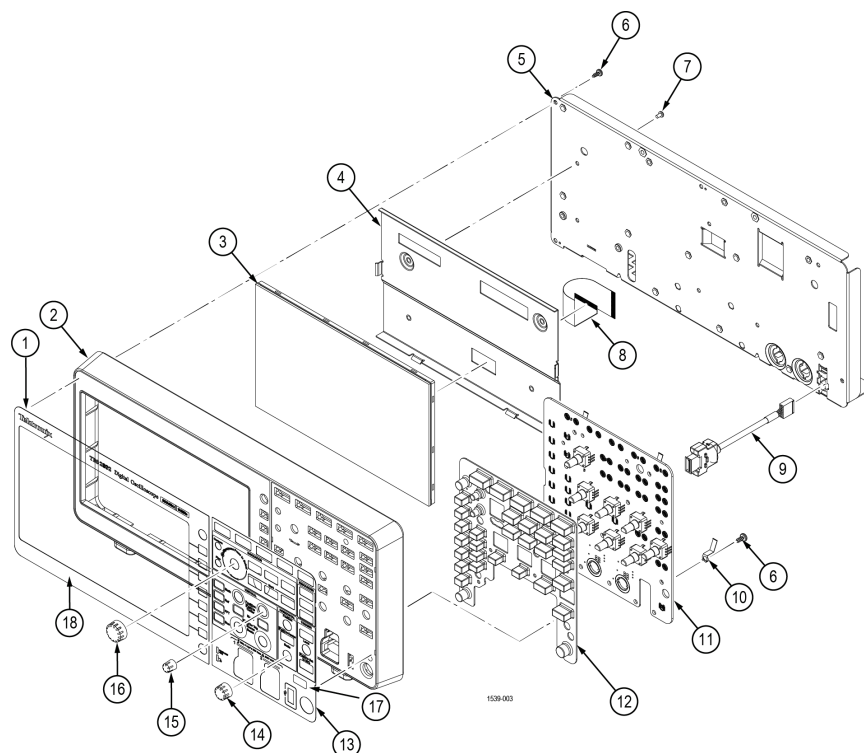

Figure 8: Two channel models; front half

Table 6: Two-channel model parts: front panel, display, and front chassis

Fig. & index number	Tektronix part number	Serial no. effective	Serial no. discont'd	Qty ¹	Name & description
5-3-1	335-4111-xx			1	LABEL, BLACK FRAME-B2 9 INCH DISPLAY, TBS2102, SAFETY CONTROLLED
-2	850-0439-xx			1	FRONT CASE, 2CH
-3	850-0312-xx			1	FRAME ASSEMBLY; DISPLAY; TBS2K
-4	407-5760-xx			1	BRACKET, DISPLAY MOUNT
-5	441-2844-xx			1	CHASSIS, MAIN, SAFETY CONTROLLED
-6	211-1273-xx			22 ²	SCREW,PT; K35-1.57, PAN HEAD, STL, ZNPL, T-15
-7	211-1272-xx			43 ²	SCREW, MACHINE; 6-32 X 0.250, PNH, STL, ZNPL, T-15 TORX DR
-8	174-6941-xx			1	CABLE, DISPLAY, FFC, 50POS
-9	174-5411-xx			1	CABLE EXTENSION, USB-HOST
-10	131-8139-xx			7	CONTACT, SPRING; FRONT PANEL ELEC
-11	870-1161-xx			1	FRONT PANEL B2 BOARD
-12	260-3114-xx			1	SWITCH, KEYPAD, ELASTOMERIC FRONT PANEL

Table continued...

Fig. & index number	Tektronix part number	Serial no. effective	Serial no. discont'd	Qty ¹	Name & description
-13	335-4042-xx			1	LABEL, FRONT PANEL 2CH
	335-4137-xx			1	MARKER, IDENTIFICATION FRONT PANEL OVERLAY, FRENCH
	335-4146-xx			1	MARKER, IDENTIFICATION FRONT PANEL OVERLAY, RUSSIAN
	335-4138-xx			1	MARKER, IDENTIFICATION FRONT PANEL OVERLAY, ITALIAN
	335-4139-xx			1	MARKER, IDENTIFICATION FRONT PANEL OVERLAY, GERMANY
	335-4140-xx			1	MARKER, IDENTIFICATION FRONT PANEL OVERLAY, SPANISH
	335-4141-xx			1	MARKER, IDENTIFICATION FRONT PANEL OVERLAY, JAPANESE
	335-4143-xx			1	MARKER, IDENTIFICATION FRONT PANEL OVERLAY, SIMPLE CHINESE
	335-4144-xx			1	MARKER, IDENTIFICATION FRONT PANEL OVERLAY, STANDARD CHINESE
	335-4145-xx			1	MARKER, IDENTIFICATION FRONT PANEL OVERLAY, KOREAN
-14	366-0935-xx			3	ASSEMBLY, KNOB; .685 IN DIAMETER
-15	366-0934-xx			4	ASSEMBLY, KNOB; .470 IN DIAMETER
-16	366-0936-xx			1	ASSEMBLY, KNOB; .925 IN DIAMETER
-17	335-4120-xx			1	LABEL, NOMENCLATURE, TBS2072B
	335-4119-xx			1	LABEL, NOMENCLATURE, TBS2102B
	335-4118-xx			1	LABEL, NOMENCLATURE, TBS2202B
-18	335-4111-xx			1	LABLE, BLACK FRAME-B2

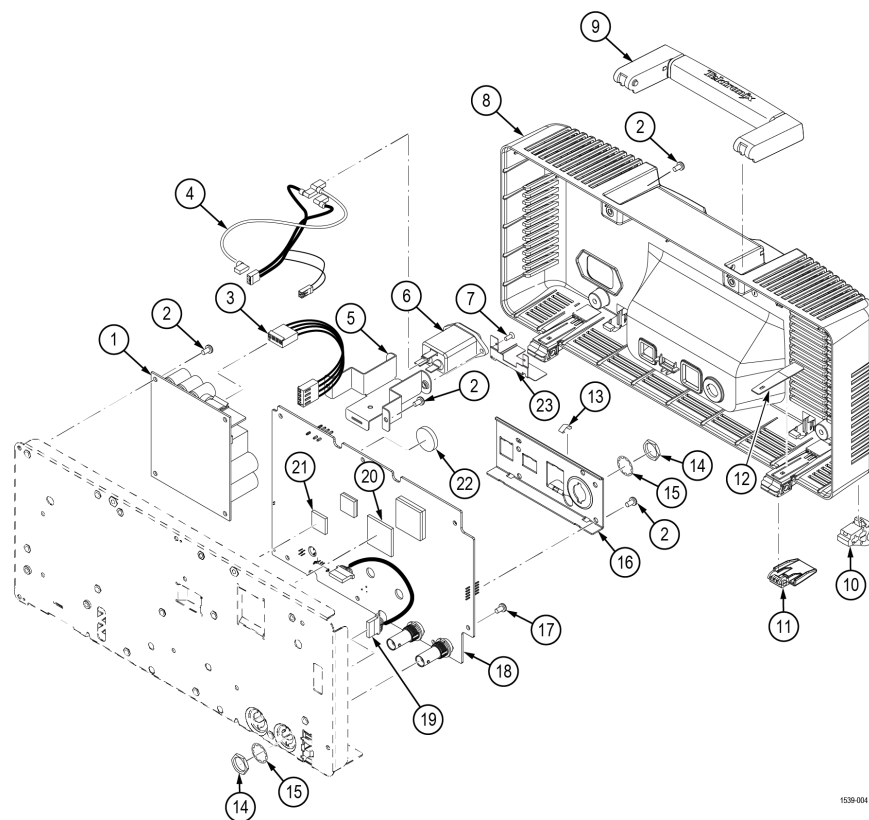

Figure 9: Two channel models; rear half

Table 7: Two-channel model parts: power supply, main board, AC connector/filter, rear cover

Fig. & index number	Tektronix part number	Serial no. effective	Serial no. discont'd	Qty ¹	Name & description
5-4-1	119-8488-xx			1	POWER SUPPLY; AC-DC, INTERNAL; 90-264 VAC 47-63 HZ, 103-127 VAC, 360-440 HZ IN; +12V 5A4, 65W OUT; SAFETY CONTROLLED
-2	211-1272-xx			43 ²	SCREW, MACHINE; 6-32 X 0.250, PNH, STL, ZNPL, T-15 TORX DR
-3	174-6877-xx			1	CABLE POWER SUPPLY WITH MAIN BOARD, SAFETY CONTROLLED
-4	174-6920-xx			1	CABLE ASSEMBLY (LINE INPUT), SAFETY CONTROLLED
-5	407-5916-xx			1	BRACKET, FILTER, SAFETY CONTROLLED
-6	119-7086-xx			1	FILTER, EMI; AC LINE CONNECTOR/INPUT FILTER; 6.0A, 120-250 VAC, DC-400 HZ
-7	211-0718-xx			2	SCREW, MACHINE; 6-32 X 0.312, FLH100, STEEL, ZINC FINISH, T-10 TORX DR
-8	850-0441-xx			1	CASE, REAR, SAFETY CONTROLLED

Table continued...

Fig. & index number	Tektronix part number	Serial no. effective	Serial no. discount'd	Qty ¹	Name & description
-9	367-0598-xx			1	HANDLE, CARRYING OVERMOLDED, SAFETY CONTROLLED
-10	348-1909-xx			2	FOOT REAR; SAFETY CONTROLLED
-11	348-2209-xx			2	FOOT, FRONT CABINET, HINGED, SAFETY CONTROLLED
-12	214-5148-xx			2	SPRING FRONT FOOT
-13	131-6643-xx			4	CONTACT, ELECTRICAL
-14	220-0265-xx			3	NUT, PLAIN, HEX; 0.5-28 X 0.625 HEX, BRS, NKL PL
-15	210-1039-xx			3	WASHER, LOCK INTERNAL TOOTH
-16	407-5915-xx			1	BRACKET, REAR BNC IN MAIN BOARD
-17	211-1273-xx			6	SCREW, PT; K35-1.57, PAN HEAD, STL, ZNPL, T-15
-18	870-1175-xx			1	CIRCUIT BOARD ASSY; MAIN B2 BOARD
-19	174-6699-xx			1	CABLE CONNECTION, FRONT- PANEL & MAIN BOARD
-20	253-0571-xx			1	THERMAL INTERFACE MATERIAL SQUARE, 27X27MM
-21	253-0570-xx			1	THERMAL INTERFACE MATERIAL SQUARE, 15X15MM
-22	146-0148-xx			1 ⁴	BATTERY, DRY: 3 VOLT, 150MAH, LITHIUM, LEADED BUTTON CELL, SAFETY CONTROLLED
-23				1	
-N/A	119-8771-xx			1 ⁵	WIFI USB DONGLE FOR TBS